

TurnLine

**T-CBN HARDBREAKER HP**

www.tungaloy.de

Tungaloy Report TG0818-518-D1

**SM<sup>★</sup>TOOLS<sup>®</sup>**

# NEUE Spanformstufe für effizientes Hartdrehen

Member IMC Group  
**Tungaloy**



**INDUSTRY 4.0**  
*FEED the SPEED!*

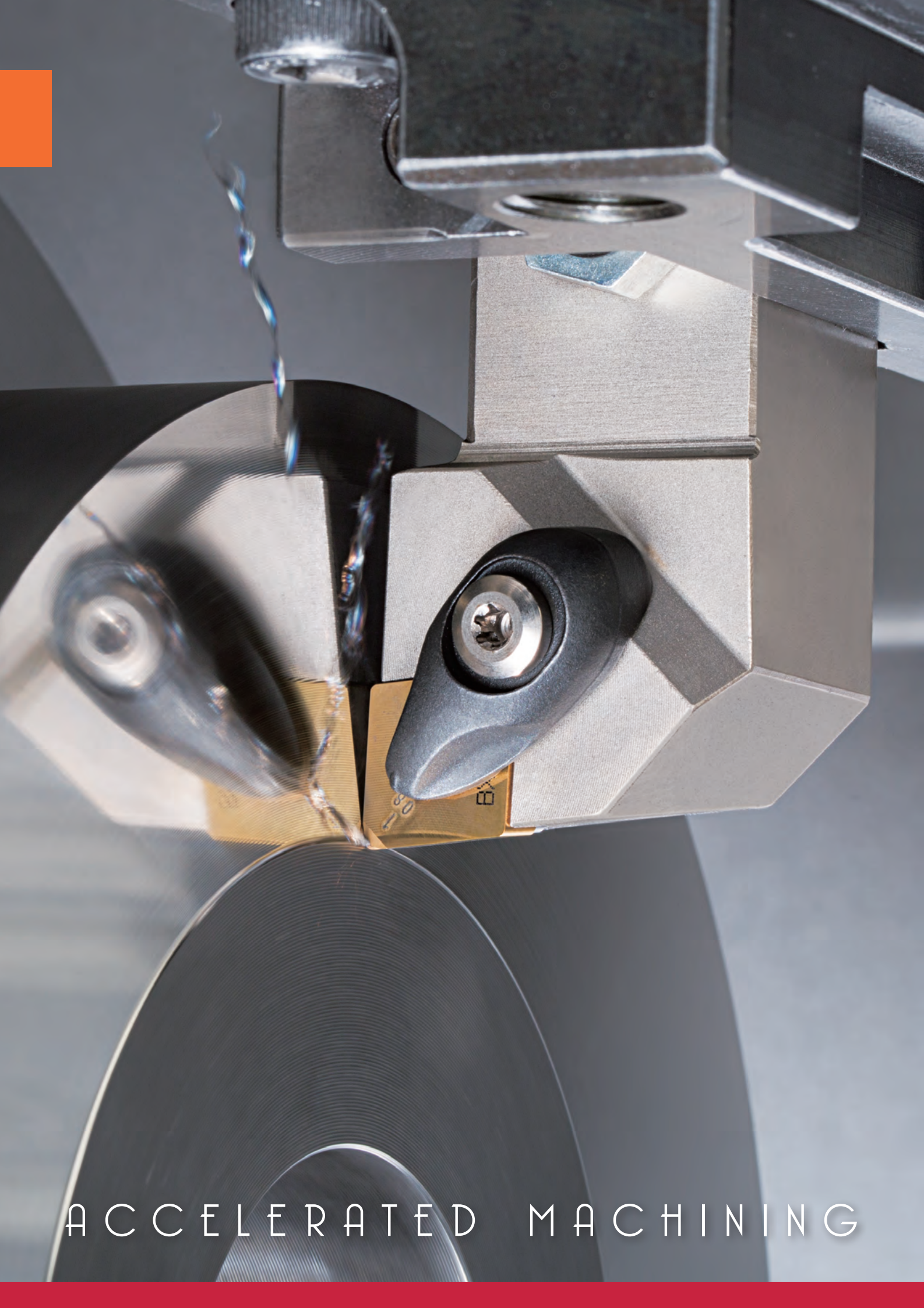

ACCELERATED MACHINING

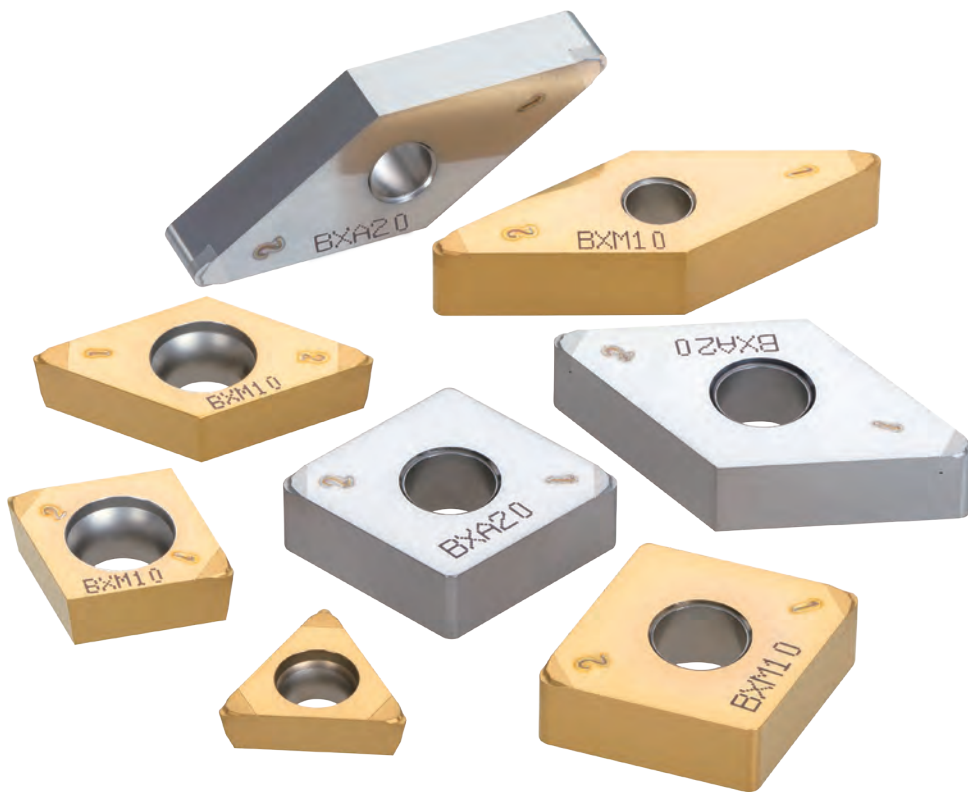

---

Innovative 3D Spanformstufe für  
effiziente Spankontrolle

---

## Neuer HP Spanformstufe Für die Schlichtbearbeitung von gehärtetem Stahl

- 1 Durch die Spanformstufe wird die auf die Schneidkante wirkende Kraft signifikant reduziert und Standzeiten deutlich erhöht.
- 2 Weicher Schnitt und niedrige Schnittkräfte zur Einhaltung engster Toleranzen ohne Abweichungen
- 3 Die **HP** Spanformstufe, mit Wiper Schneide erzielt exzellente Oberflächengüte und ausgezeichnete Spankontrolle.

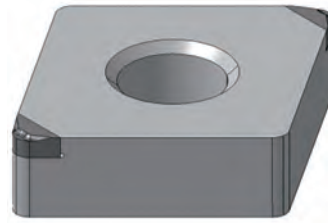

Optimierte  
Schneidkanten-  
präparation für  
geringste  
Schnittkräfte

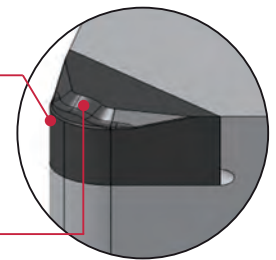

HP Spanformstufe

### Für negative Wendeschneidplatten

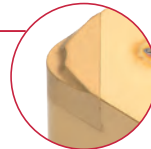
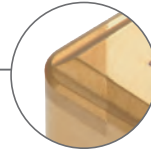
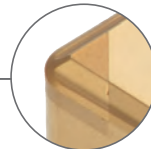
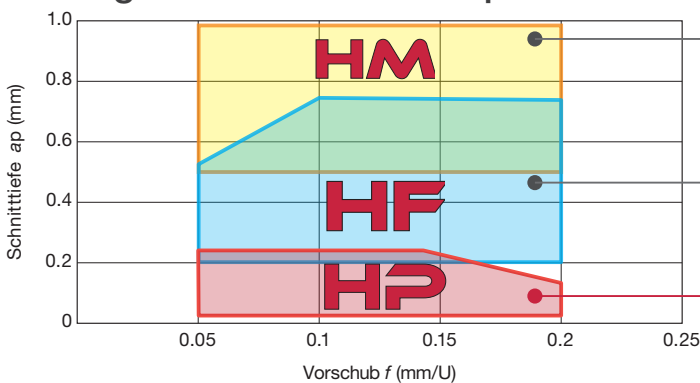

**HP**

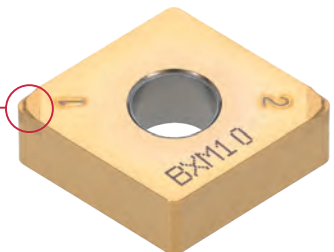

### Für positive Wendeschneidplatten

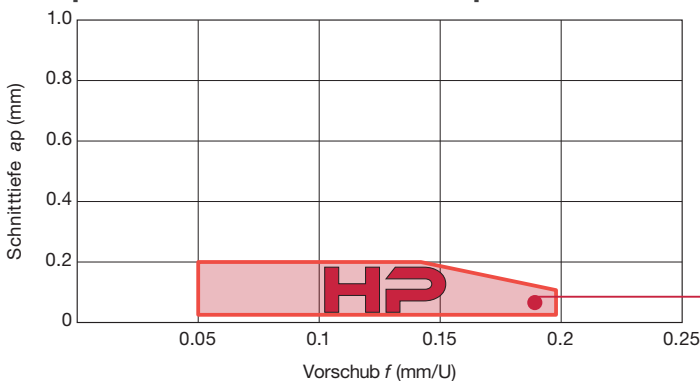

**HP**

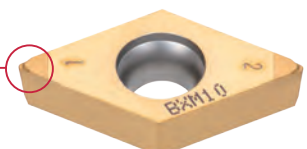

## SCHNITTLEISTUNG

Stabile Spankontrolle für lange Standzeiten

**HARDBREAKER HP**



---



**Vs.**

40 Min.

↓

80 Min.

Mitbewerber



---

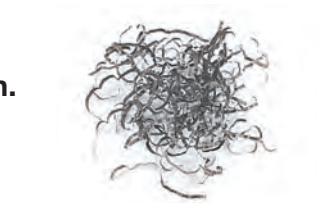

**HP**

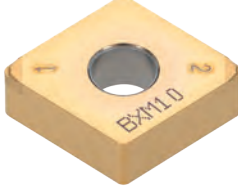

Wendeschnidplatte : 2QP-CNGM120408-HP BXM10  
 Werkstoff : 18CrMo4 58HRC  
 Schnittgeschwindigkeit :  $V_c = 180$  m/min  
 Vorschub :  $f = 0.15$  mm/U  
 Schnitttiefe :  $a_p = 0.15$  mm  
 Halter : ACLNR2525M12-A  
 Kühlung : Emulsion  
 Bearbeitung : Kontinuierliche Schnitt/Außen

## Antivibration

→ Verhindert Vibrationen und ermöglicht beste Oberflächengüte

### HARDBREAKER HP



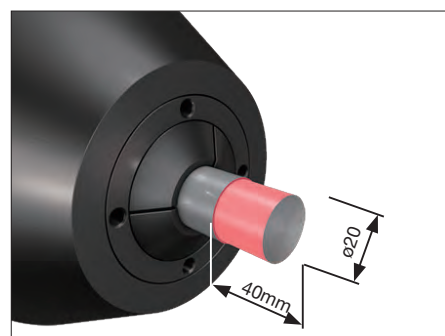
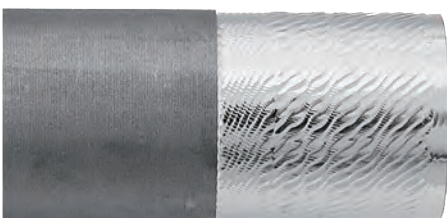

Niedrige Schnittkräfte ermöglichen vibrationsfreie Bearbeitung

Mitbewerber (ohne Spanformstufe)

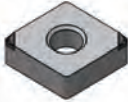
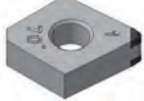
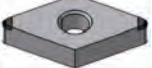

Wendeschnidplatte : 2QP-CNGM120408-HP BXM10  
 Werkstoff : 18CrMo4 58HRC  
 Schnittgeschwindigkeit :  $V_c = 150$  m/min  
 Vorschub :  $f = 0.15$  mm/U  
 Schnitttiefe :  $a_p = 0.15$  mm  
 Bearbeitung : Kontinuierliche Schnitt/Außen

## WENDESCHNEIDPLATTEN

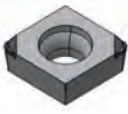
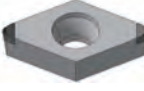
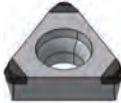
Form	Katalog Nr.	Schneidstoff		Innenkreis	Dicke	Loch-Ø	Eckenradius	CBN Länge
		Beschichtet						
		BXM10	BXA20					
		IC	S	D1	RE	LE		
	2QP-CNGM120404-HP	●	●	12.7	4.76	5.16	0.4	2.3
	2QP-CNGM120408-HP	●	●	12.7	4.76	5.16	0.8	2.2
	2QP-CNGM120408WL-HP	●	●	12.7	4.76	5.16	0.8	2.2
	2QP-GNGG120404-HP	●	●	12.7	4.76	5.16	0.4	2.3
	2QP-GNGG120408-HP	●	●	12.7	4.76	5.16	0.8	2.2
	2QP-DNGM150404-HP	●	●	12.7	4.76	5.16	0.4	2.5
	2QP-DNGM150408-HP	●	●	12.7	4.76	5.16	0.8	2.1
	3QP-TNGM160404-HP	●	●	9.525	4.76	3.81	0.4	2.2
	3QP-TNGM160408-HP	●	●	9.525	4.76	3.81	0.8	1.9
	2QP-VNGM160408-HP	●	●	9.525	4.76	3.81	0.8	2.2
	2QP-CCGT060204-HP	●	●	6.35	2.38	2.8	0.4	2.3
	2QP-CCGT09T304-HP	●	●	9.525	3.97	4.4	0.4	2.3
	2QP-CCGT09T308-HP	●	●	9.525	3.97	4.4	0.8	2.2
	2QP-CCGT09T304WL-HP	●	●	9.525	3.97	4.4	0.4	2.3
	2QP-CCGT09T308WL-HP	●	●	9.525	3.97	4.4	0.8	2.2
	2QP-DCGT070204-HP	●	●	6.35	2.38	2.8	0.4	2.5
	2QP-DCGT11T304-HP	●	●	9.525	3.97	4.4	0.4	2.5
	2QP-DCGT11T308-HP	●	●	9.525	3.97	4.4	0.8	2.1
	3QP-TPGT110304-HP	●	●	6.35	3.18	3.4	0.4	2.2
	3QP-TPGT110308-HP	●	●	6.35	3.18	3.4	0.8	1.9

● Neues Produkt  
● Markteinführung in 2018

## STANDARD SCHNITTDATEN

ISO	Schneidstoff	Bearbeitung	Schnittgeschwindigkeit Vc(m/min)	Schnitttiefe ap (mm)	Vorschub f (mm/U)
<b>H</b>	BXM10	Kontinuierlich	120 - 350	0.05 - 0.20	0.05 - 0.20
	BXA20	Kontinuierlich	70 - 180	0.05 - 0.20	0.05 - 0.20
		Leicht unterbrochen	70 - 180	0.05 - 0.20	0.05 - 0.20

## PRAKTISCHE BEISPIELE

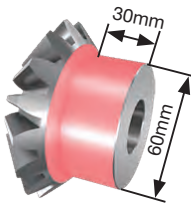
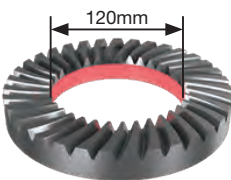
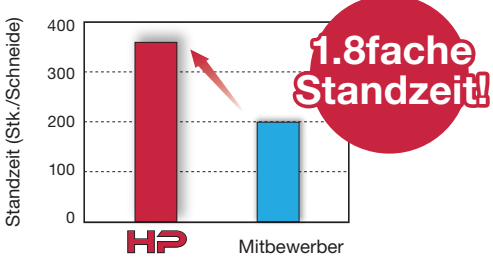
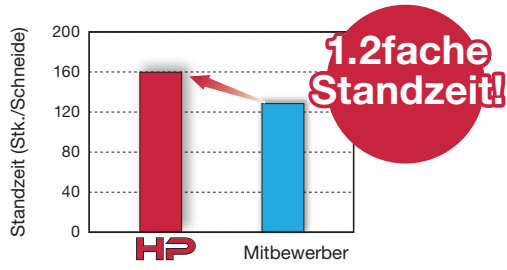
Werkstück		Kegelradgetriebe	Zahnrad
Wendeschneidplatte		2QP-CNGM120408-HP	2QP-CNGM120408WL-HP
Schneidstoff		BXA20	BXA20
Werkstoff		18CrMo4 (HRC58)	18CrMo4 (HRC58)
			
Schnittbedingungen	Schnittgeschwindigkeit: Vc (m/min)	160	150
	Vorschub : f (mm/U)	0.10	0.12
	Schnitttiefe : ap (mm)	0.15	0.18
	Kühlung	Emulsion	ohne
Resultat			

## Tungaloy Corporation (Head office)

11-1 YoUnterlagea-Kogyodanchi  
Iwaki-city, FukuUnterlagea, 970-1144 Japan  
Tel.: +81-246-36-8501  
Fax: +81-246-36-8542  
www.tungaloy.co.jp

## Tungaloy America, Inc.

3726 N Ventura Drive  
Arlington Heights, IL 60004, U.S.A.  
Tel.: +1-888-554-8394  
Fax: +1-888-554-8392  
www.tungaloyamerica.com

## Tungaloy Canada

432 Elgin St. Unit 3  
Brantford, Ontario N3S 7P7, Canada  
Tel.: +1-519-758-5779  
Fax: +1-519-758-5791  
www.tungaloy.co.jp/ca

## Tungaloy de Mexico S.A.

C Los Arellano 113,  
Parque Industrial Siglo XXI  
Aguascalientes, AGS, Mexico 20290  
Tel.: +52-449-929-5410  
Fax: +52-449-929-5411  
www.tungaloy.co.jp/mx

## Tungaloy do Brasil Ltda.

Rua dos Sabias N.104  
13280-000 Vinhedo, São Paulo, Brazil  
Tel.: +55-19-38262757  
Fax: +55-19-38262757  
www.tungaloy.co.jp/br

## Tungaloy Germany GmbH

An der Alten Ziegelei 1  
D-40789 Monheim, Germany  
Tel.: +49-2173-90420-0  
Fax: +49-2173-90420-19  
www.tungaloy.de

## Tungaloy France S.A.S.

ZA Courtaboeuf - Le Rio  
1 rue de la Terre de feu  
F-91952 Courtaboeuf Cedex, France  
Tel.: +33-1-6486-4300  
Fax: +33-1-6907-7817  
www.tungaloy.fr

## Tungaloy Italia S.r.l.

Via E. Andolfato 10  
I-20126 Milano, Italy  
Tel.: +39-02-252012-1  
Fax: +39-02-252012-65  
www.tungaloy.it

## Tungaloy Czech s.r.o.

Turanka 115  
CZ-627 00 Brno, Czech Republic  
Tel.: +420-532 123 391  
Fax: +420-532 123 392  
www.tungaloy.cz

## Tungaloy Ibérica S.L.

C/Miquel Servet, 43B, Nau 7  
Pol. Ind. Bufalvent  
ES-08243 Manresa (BCN), Spain  
Tel.: +34 93 113 1360  
Fax: +34 93 876 2798  
www.tungaloy.es

## Tungaloy Scandinavia AB

S:t Lars Väg 42A  
SE-22270 Lund, Sweden  
Tel.: +46-462119200  
Fax: +46-462119207  
www.tungaloy.se

## Tungaloy Rus, LLC

36-D Harkovsky Lane  
308009 Belgorod, Russia  
Tel.: +7 4722 24 00 07  
Fax: +7 4722 24 00 08  
www.tungaloy.co.jp/ru

## Tungaloy East LLC

Stachek str., h.4, office 2, Ekaterinburg,  
620017, Russia  
Tel.: +7-343-389-13-22  
Fax: +7-343-278-94-35  
www.tungaloy.co.jp/ru

## Tungaloy Polska Sp. z o.o.

ul. GeNeuška 24  
03-963 Warszawa, Poland  
Tel.: +48-22-617-0890  
Fax: +48-22-617-0890  
www.tungaloy.co.jp/pl

## Tungaloy U.K. Ltd

The Technology Centre,  
Wolverhampton Science Park  
Glaisher Drive, Wolverhampton  
West Midlands WV10 9RU, UK  
Tel.: +44 121 309 0163  
Fax: +44 121 270 9694  
www.tungaloy.co.jp/uk  
salesinfo@tungaloyuk.co.uk

## Tungaloy Hungary Kft

Erzsébet királyné útja 125  
H-1142 Budapest, Hungary  
Tel.: +36 1 781-6846  
Fax: +36 1 781-6866  
www.tungaloy.co.jp/hu  
info@tungaloytools.hu

## Tungaloy Turkey

Dudullu, OSB 4. Cad No:4  
34776 Umraniye Istanbul, TURKEY  
Tel.: +90 216 540 04 67  
Fax: +90 216 540 04 87  
www.tungaloy.com.tr  
info@tungaloy.com.tr

## Tungaloy Benelux b.v.

Tjalk 70, NL-2411 NZ Bodegraven,  
Netherlands  
Tel.: +31 172 630 420  
Fax: +31 172 630 429  
www.tungaloy-benelux.com

## Tungaloy Croatia

Josipa Kozarca 4  
10432 Bregana, Croatia  
Tel.: +385 1 3326 604  
Fax: +385 1 3327 683  
www.tungaloy.hr

## Tungaloy Cutting Tool (Shanghai) Co., Ltd.

Rm No 401 No.88 Zhabei  
Jiangchang No.3 Rd  
Shanghai 200436, China  
Tel.: +86-21-3632-1880  
Fax: +86-21-3621-1918  
www.tungaloy.co.jp/tcts

## Tungaloy Cutting Tool (Thailand) Co., Ltd.

11th Floor, Sorachai Bldg. 23/7  
Soi Sukhumvit 63  
Klongtonnue, Wattana  
Bangkok 10110, Thailand  
Tel.: +66-2-714-3130  
Fax: +66-2-714-3134  
www.tungaloy.co.th

## Tungaloy Singapore (Pte.), Ltd.

31 Kaki Bukit Road 3, #05-19 TechLink  
Singapore 417818  
Tel.: +65-6391-1833  
Fax: +65-6299-4557  
www.tungaloy.co.jp/tspl

## Tungaloy Vietnam

31 Kaki Bukit Road 3, #05-19 TechLink  
Singapore 417818  
Tel.: +65-6391-1833  
Fax: +65-6299-4557  
www.tungaloy.co.jp/tspl

## Tungaloy India Pvt. Ltd.

Indiabulls Finance Centre,  
Unit # 902-A, 9th Floor,  
Tower 1, Senapati Bapat Marg,  
Elphinstone Road (West),  
Mumbai -400013, India  
Tel.: +91-22-6124-8804  
Fax: +91-22-6124-8899  
www.tungaloy.co.jp/in

## Tungaloy Korea Co., Ltd

#1312, Byucksan Digital Valley 5-cha  
Beotkkot-ro 244, Geumcheon-gu  
153-788 Seoul, Korea  
Tel.: +82-2-2621-6161  
Fax: +82-2-6393-8952  
www.tungaloy.co.jp/krr

## Tungaloy Malaysia Sdn Bhd

50 K-2, Kelana Mall, Jalan SS6/14  
Kelana Jaya, 47301  
Petaling Jaya, Selangor Darul Ehsan  
Malaysia  
Tel.: +603-7805-3222  
Fax: +603-7804-8563  
www.tungaloy.co.jp/my

## Tungaloy Australia Pty Ltd

PO Box 2232, Rowville,  
Victoria 3178, Australia  
Tel.: +61-3-9755-8147  
Fax: +61-3-9755-6070  
www.tungaloy.com.au

## PT. Tungaloy Indonesia

Kompleks Grand Wisata Block A,A-10 No.3-5  
Cibitung, Bekasi 17510, Indonesia  
Tel.: +62-21-8261-5808  
Fax: +62-21-8261-5809  
www.tungaloy.co.jp/id

Schnyder + Minder AG | Zielmattenring 11 | CH-4563 Gerlafingen | Phone: +41 31 832 77 00 | info@smtools.ch | www.smtools.ch

Ausgehändigt durch:

# SM TOOLS®

DOWNLOAD  
Dr. Carbide App



Available on the  
App Store



GET IT ON  
Google play

FIND US ON THE CLOUD!  
machiningcloud.com



ISO14001 Certified  
EC97J1123

1997.11.26